

FREE STANDING PRE-HEAT UNIT

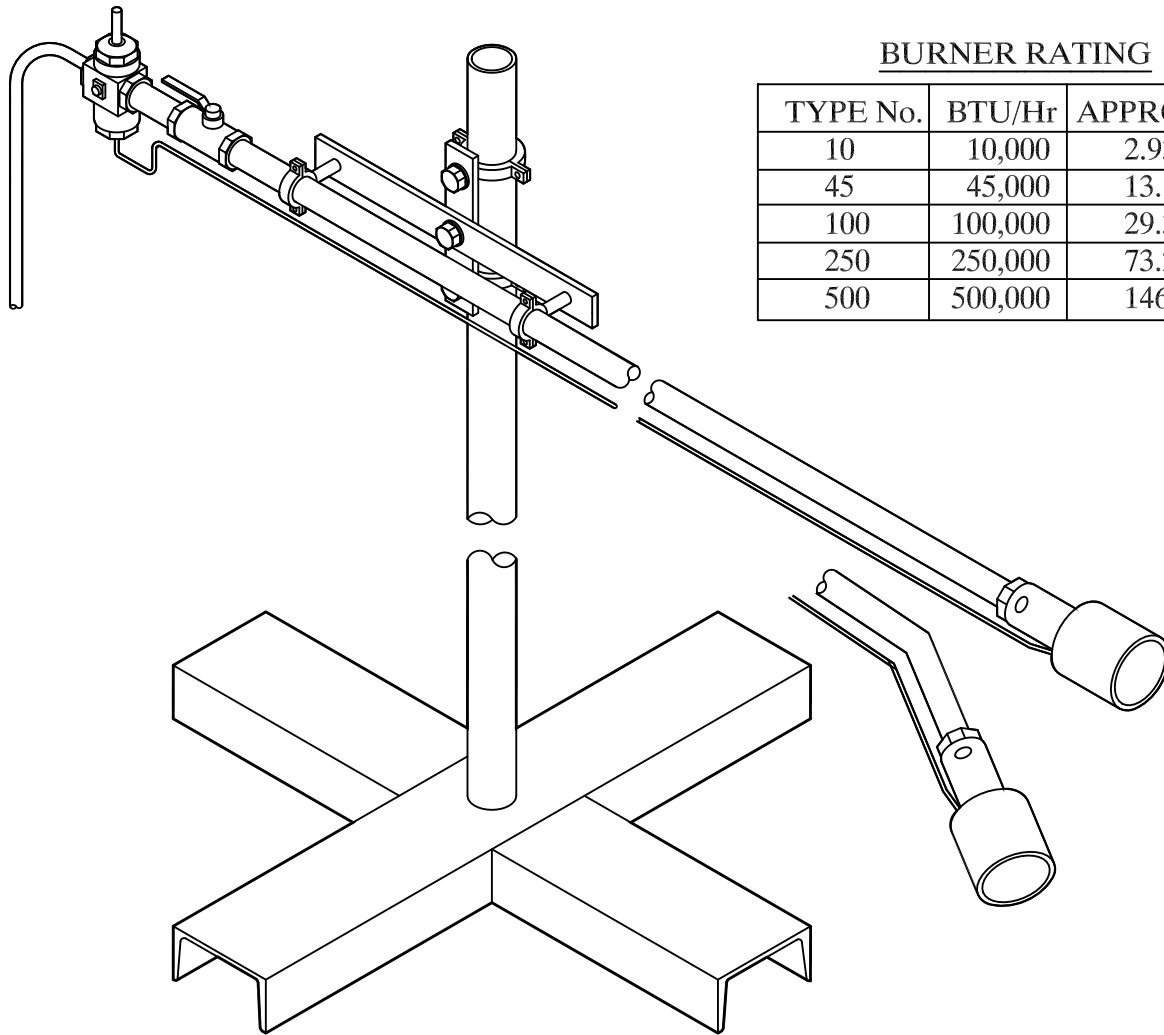

BURNER RATING

TYPE No.	BTU/Hr	APPROX Kw
10	10,000	2.93
45	45,000	13.18
100	100,000	29.31
250	250,000	73.27
500	500,000	146.54

A fully adjustable free standing unit for pre-heating die sets on horizontal centrifugal casting machines.

The unit consists of a single burner jet (see table for different sizes available) connected via a rigid steel tube, (length dependant on die set) complete with manual shut-off valve and a safety valve with thermocouple which automatically shuts of the gas supply when no flame is detected.

The burner jets height and angle is fully adjustable on the support frame to give the best position for heating. (Sraight or 45° versions available)



HILLTOP WORKS,
EASTERN AVENUE, LICHFIELD,
STAFFORDSHIRE, WS13 6UY, ENGLAND

Telephone +44(0)1543 418701. Fax +44(0)1543 418703.

Email: sales@gibsoncentritech.co.uk

Web site: www.gibsoncentritech.co.uk

DESIGNERS and MANUFACTURERS of CENTRIFUGAL CASTING MACHINES